

Title Theory and applications of millimeter
wave identification

Author(s) Pursula, Pekka; Viikari, Ville;
Vähä-Heikkilä, Tauno

Citation Proceedings of International
Semiconductor Conference,
CAS 2010. Sinaia, Romania,
11-13 Oct. 2010, pp. 53-56.

Date 2010

Rights Copyright © [2010] IEEE.
Reprinted from Proceedings of
International Semiconductor
Conference, CAS 2010. Sinaia,
Romania, 11-13 Oct. 2010.
ISBN 978-1-4244-5781-6.

This material is posted here with permission of the IEEE. Such permission of the IEEE does not in any way imply IEEE endorsement of any of VTT Technical Research Centre of Finland's products or services. Internal or personal use of this material is permitted. However, permission to reprint/republish this material for advertising or promotional purposes or for creating new collective works for resale or redistribution must be obtained from the IEEE by writing to pubspermissions@ieee.org.

By choosing to view this document, you agree to all provisions of the copyright laws protecting it.

<p>VTT http://www.vtt.fi P.O. box 1000 FI-02044 VTT Finland</p>	<p>By using VTT Digital Open Access Repository you are bound by the following Terms & Conditions.</p> <p>I have read and I understand the following statement:</p> <p>This document is protected by copyright and other intellectual property rights, and duplication or sale of all or part of any of this document is not permitted, except duplication for research use or educational purposes in electronic or print form. You must obtain permission for any other use. Electronic or print copies may not be offered for sale.</p>
---	---

THEORY AND APPLICATIONS OF MILLIMETER WAVE IDENTIFICATION

P. Pursula, V. Viikari, T. Vähä-Heikkilä

VTT Technical Research Centre of Finland

Tietotie 3, 02150 Espoo, Finland

E-mail: pekka.pursula@vtt.fi

Abstract

Millimeter wave identification, or MMID, extends backscattering communication from UHF RFID to millimeter waves. The paper presents fundamental limitations of the MMID range based on power transfer to and scattering from the transponder. Developments towards MMID systems for several applications are presented, such as short range high data rate communication, automotive radar transponder, and passive MMID.

Keywords: backscattering, Millimeter Wave Identification, MMID, millimeter wave radar, Radio Frequency Identification, RFID.

1. INTRODUCTION

Radio frequency identification (RFID) has rapidly spread throughout the industry as a means to identify and track goods. The success of passive UHF RFID is based on robust identification with inexpensive (even less than 10 Euro cent) transponders. UHF RFID provides a range of even 10 meters with data rate up to 640 kbit/s, but does not offer efficient locating capabilities.

Millimeter Wave Identification (MMID) updates the RFID system to millimeter waves [1]. The higher carrier frequency has several advantages: First, smaller antennas enable miniaturized transponders as well as compact reader modules. Second, antenna arrays can be used to achieve (steerable) narrow beam reader antennas, which enable efficient transponder localization. More relaxed radio regulations e.g. at 60 GHz enable also high data rate communication.

The drawback of a higher carrier frequency is that a low-gain antenna does not provide a long read-out distance due to a very small effective antenna aperture and thus inefficient power transfer from a reader to a tag. Hence MMID system design is strongly power-constrained.

The next Section examines the power transfer between the reader and the transponder, as well as the backscattering modulation, and considers the effect of a millimeter wave carrier frequency. Applications from high data rate short distance MMID system to automotive radar compatible

transponder and location sensing are discussed. Developments towards these applications of the MMID technology are presented in third Section.

2. READ RANGE

The transponder does not have any active millimeter wave source, but the uplink communication is based on the modulation of the reflected signal from the tag, that is, the modulated backscattering. Hence the reader device resembles a continuous wave radar, as presented in Fig. 1. Passive transponders rectify DC power from the reader transmission, whereas semipassive transponders have a battery as a power source.

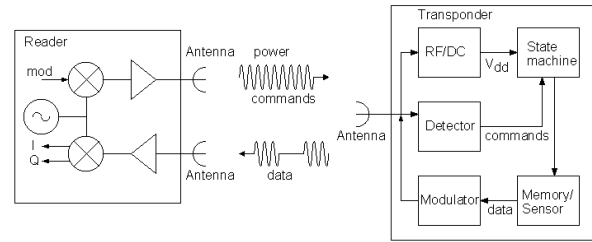

Fig. 1. Block diagram of a passive MMID system.

RFID and MMID systems have two power constraints to the read range: First, the reader transmission must have high enough intensity at the transponder for passive operation, or in case of semipassive transponder, for detecting the amplitude modulated commands in the reader transmission. Second, the backscattered signal from the transponder must exceed the receiver sensitivity of the reader. With the aid of a simple series model of the transponder antenna – load system, the power limits can be described analytically by the effective aperture A_e and the radar cross section of the transponder [1]:

$$A_e = \frac{G_A \lambda^2}{4\pi} \left(1 - \frac{1}{2} \left[|\Gamma_1|^2 + |\Gamma_2|^2 \right] \right), \quad (1)$$

$$\sigma_m = \frac{G_A^2 \lambda^2}{16\pi} |\Gamma_1 - \Gamma_2|^2 = \frac{G_A^2 \lambda^2}{4\pi} m.$$

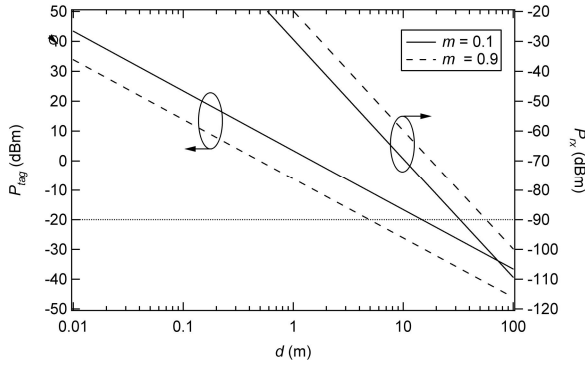

Fig. 2. Power received by the transponder (P_{tag}) and the reader (P_{rx}) as a function of a distance at 865 MHz. $G_{tx}P_{tx} = 33$ dBm_{erp}, $G_{rx} = 8$ dBi, $G_A = 0$ dBi.

Here the G_A is the transponder antenna gain, λ the wavelength, $\Gamma_{1,2}$ the reflection coefficients of the two impedance states of the antenna load, and m the modulation index. The effective aperture and the radar cross section have been calculated for a equal on- and off-cycle length square modulation of the load, and the radar cross section is given only for the modulated scattering, i.e. structural ‘constant’ scattering is neglected).

With Friis and radar equations, (1) transform to limitations in read range d :

$$d_{down} = \frac{\lambda}{4\pi} \sqrt{\frac{G_{tx}G_A P_{rx}}{P_{tag}^0} \left(1 - \frac{1}{2} [|\Gamma_1|^2 + |\Gamma_2|^2]\right)}, \quad (2)$$

$$d_{up} = \frac{\lambda}{4\pi} \sqrt[4]{\frac{G_{rx}G_{tx}G_A^2 P_{tx}}{4P_{rx}^0} |\Gamma_1 - \Gamma_2|^2}.$$

Here the G_{rx} and G_{tx} are the gains of the reader transmission and reception antennas, and P_{tag}^0 and P_{rx}^0 the sensitivities of the transponder and the receiver, respectively.

The upper equation in (2) defines the maximum range limited by the power transfer from the reader to the transponder, i.e. the downlink range. Similarly, the lower equation states the maximum range for the backscattered signal to be received by the reader, i.e. the uplink range. The overall maximum range of the system is the shorter of these two.

Eqs. (2) illustrate an interesting characteristic of carrier frequency scaling. Because both range equations are directly proportional to the wavelength of the system, the range diminishes with rising carrier frequency. On the other hand, smaller wavelength enables higher gain antennas, which increases range at higher frequencies.

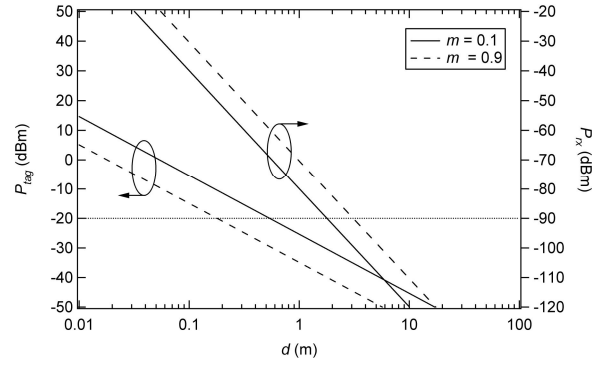

Fig. 3. Power received by the transponder (P_{tag}) and the reader (P_{rx}) as a function of distance at 60 GHz. $G_{tx}P_{tx} = 33$ dBm_{erp}, $G_{rx} = 15$ dBi, $G_A = 8$ dBi.

The read ranges at UHF (865 MHz) and millimeter waves (60 GHz) have been visualized in Figs. 2 and 3 by plotting the power received by the transponder (P_{tag}) and the reader (P_{rx}) as a function of distance with typical system parameters. The vertical line stands for transponder and reader sensitivity, -20 dBm and -90 dBm, respectively, which represent the state-of-the-art values for UHF RFID.

The range of both RFID and MMID systems is limited by the power transfer to the passive transponder. If semipassive transponders are used, the reader sensitivity becomes the limiting factor. The reader sensitivity is limited by the receiver white noise, and is thus dependent on the data bandwidth. Low data rate semipassive transponders can reach ranges of several tens of meters. Furthermore, an automotive FMCW radar can be used as the reader with small modifications.

At very short distances, the signal to noise ratio of the received signal is huge. This allows increasing the data rate to tens or hundreds Mbit/s.

3. APPLICATIONS

This Section introduces developments towards MMID applications from high data rate communication to longer range identification systems with localization.

3.1. HIGH DATA RATE COMMUNICATIONS

Semipassive transponders can be realized with a single diode as the millimeter wave front end, as presented in [1] and [2]. The diode acts as a detector and a modulator. To demonstrate the full system at 60 GHz, an MMID reader module has been implemented with CMOS components on an LTCC substrate [3]. The LTCC module includes

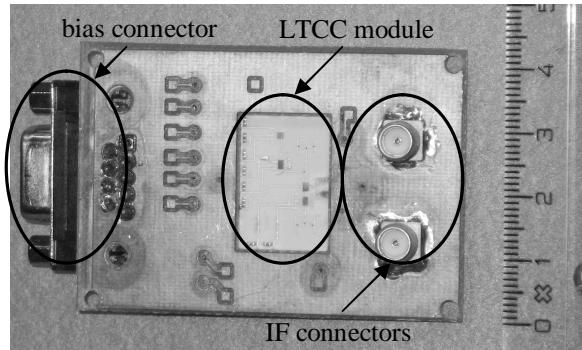

Fig. 4. MMID reader module at 60 GHz.

all the millimeter wave signals, and only bias and IF connections to the module are required.

Signal (noise) bandwidth of 20 MHz (400 MHz) and read-out across 5 cm is demonstrated with a semipassive transponder. The reader is shown in Fig. 4.

3.2. PASSIVE MMID TRANSPONDERS

A battery may limit the operation conditions, size, and life-time, and increase the price of a semipassive transponder. Passive MMID systems are emerging in the literature, e.g. in [4] a passive CMOS transponder at 60 GHz is reported. However, the protocol in the transponder is sequential, which limits the data rate to 5 kbit/s at a range of 13 mm.

A passive MMID system has been demonstrated with standard UHF RFID reader and transponder IC (ePc gen2), as presented in Fig. 5 [5]. UHF signals from a commercially available reader are converted up to and down from millimeter wave frequencies by a millimeter source (LO) and mixers. Similarly, the transponder is equipped with a passive diode mixer. Range of 30 cm has been demonstrated at 10 GHz.

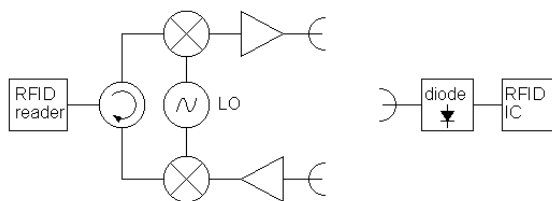

Fig. 5. Passive MMID system with external mixing elements in the reader and transponder.

3.3. TRANSPONDERS FOR AUTOMOTIVE RADARS

Current commercially available automotive radars cannot reliably classify pedestrians, cyclists and mopedists from other targets. Road safety

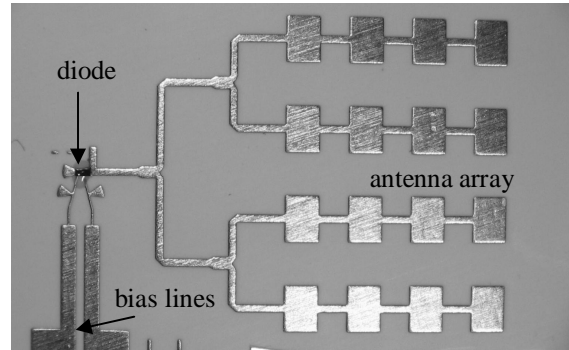

Fig. 6. Semipassive MMID transponder on LCP substrate for automotive application.

could possibly be increased by equipping the aforementioned vulnerable road users with MMID tags that a modified automotive radar could identify from other targets. Currently 24 GHz and 77 GHz frequency bands are allocated for automotive radars in Europe.

Even passive transponders have been studied for road user classification [6], but they can provide only a very limited detection range with current technology. However, semipassive MMID transponders could provide a range of several tens of meters, with the low data rate needed for classification of the vulnerable road users.

A photograph of a semipassive transponder developed for a 77-GHz automotive FMCW radar is shown in Fig. 6. The transponder consists of an antenna array on liquid crystal polymer (LCP) and a bias-modulated millimeter wave diode from United Monolithic Semiconductor. The measured modulated radar cross section (RCS) of four different prototype transponders are shown in Fig. 7. The detection range of these transponders would be 10-20 m when using a radar with comparable performance to the commercially available automotive radars.

3.4. LOCATION SENSING

UHF RFID has several advantages for location sensing in short range applications over radio protocols. RFID provides inexpensive tags with very advanced features, such as non-volatile memory and anti-collision protocols.

The relatively narrow bandwidth does not allow phase-based distance measurement and directional antennas are inconveniently big at UHF. However, MMID could provide both larger bandwidth and more directive antennas, and it could suit well for precise tag localization.

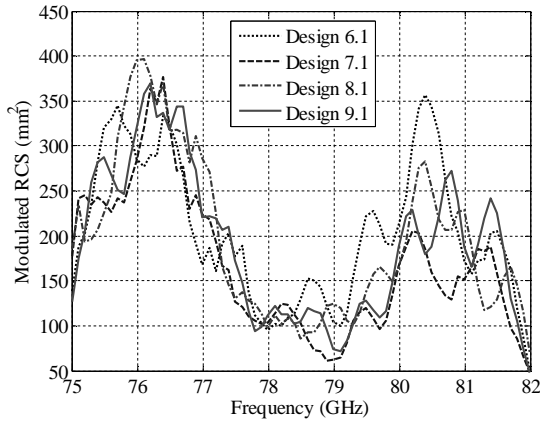

Fig. 7. Modulated radar cross sections of different prototypes of semipassive transponders.

The phase-based distance determination of generic tag is challenging due to two things. First, the dispersive properties of the tag should be known in advance. Second, the response of the tag depends on the received power, which is generally unknown. A phase-based distance determination method where the aforementioned challenges are overcome, is presented in [7]. The method is demonstrated with UHF RFID although the same principles applies for MMID as well. The determined distance of the tag with the method and without correction for dispersive properties of the tag are shown in Fig. 8.

4. CONCLUSIONS

Millimeter wave identification, or MMID, has stringent limitations to the range, because of low power operation at the transponder. Backscattering communication allows 100 Mbit/s data rate applications at short distance. Even passive operation has been achieved, to a range of 30 cm. With semipassive transponders, longer range systems for e.g. automotive application are being developed.

The scaling of CMOS to millimetre waves has made the reader modules as well as the (passive) transponders feasible for handheld and customer applications.

ACKNOWLEDGEMENT

This work was supported in part by the EU Commission under the contract FP7-ICT-2007-1-216049 of the ADOSE project.

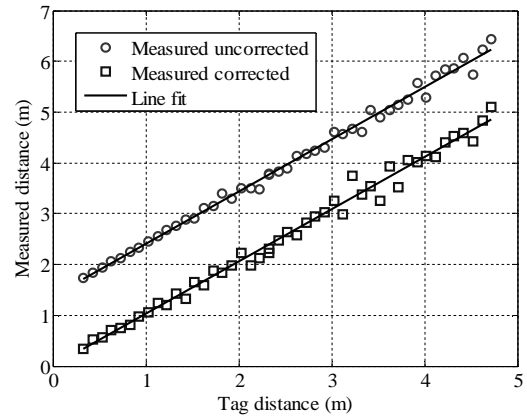

Fig. 8. The estimated uncorrected and corrected distance of the tag as a function of the true distance.

REFERENCES

- [1] P. Pursula, T. Vähä-Heikkilä, A. Müller, D. Neculoiu, G. Konstantinidis, A. Oja, J. Tuovinen, "Millimetre Wave Identification — new radio system for low power, high data rate and short range", *IEEE Transactions on Microwave theory and techniques*, vol. 56, no. 10, pp. 2221-2228, October 2008.
- [2] D. Neculoiu, G. Konstantinidis, T. Vähä-Heikkilä, A. Müller, D. Vasilache, A. Staviniadis, L. Bary, M. Dragoman, I. Petrini, C. Buiculescu, Z. Hazoupulos, N. Kornilios, P. Pursula, R. Plana, D. Dascalu, "GaAs Membrane-Supported 60 GHz Receiver with Yagi-Uda Antenna," *MEMSwave 2007, 8th International Symposium on RF MEMS and RF Microsystems*, Barcelona, June 26-29 2007, pp. 15-18.
- [3] P. Pursula, T. Karttaavi, M. Kantanen, A. Lamminen, J. Holmberg, M. Lahdes, I. Marttila, M. Lahti, A. Luukanen and T. Vähä-Heikkilä, "60 GHz Millimeter Wave Identification Reader on 90 nm CMOS and LTCC", submitted to *IEEE Transactions on Microwave Theory and Techniques*, May 2010.
- [4] S. Pellerano, J. Alvarado, Y. Palaskas, "A mm-wave power harvesting RFID tag in 90nm CMOS," *Custom Integrated Circuits Conference CICC*, 13-16 Sept. 2009, pp.677-680
- [5] P. Pursula, F. Donzelli, H. Seppä, "Passive RFID at Millimeter Waves", submitted to *IEEE Transactions on Microwave Theory and Techniques*, July 2010.
- [6] V. Viikari, J. Saebboe, S. Cheng, M. Kantanen, M. Al-Nuaimi, T. Varpula, A. Lamminen, P. Hallbjörner, A. Alastalo, T. Mattila, H. Seppä, P. Pursula, A. Rydberg, "Technical Solutions for Automotive Intermodulation Radar for Detecting Vulnerable Road Users," *IEEE 69th Vehicular Technology Conference Spring (VTC2009-Spring)*, 26-29 April 2009, Barcelona, Spain.
- [7] V. Viikari, P. Pursula, and K. Jaakkola, "Ranging of UHF RFID tag using stepped frequency read-out," *IEEE Sensors Journal*, Vol. 10, No. 9, pp. 1535 – 1539, Sept. 2010.